

OPERATOR'S MANUAL

RKW 600W SERIES

POWER SUPPLY

SINGLE OUTPUT, UNIVERSAL INPUT
SINGLE PHASE, 0.99 POWER FACTOR

KEPCO INC.
An ISO 9001 Company.

MODEL

RKW 600W SERIES

POWER SUPPLY MODELS

RKW 3.3-150K, RKW 5-120K, RKW 12-53K,
RKW 15-43K, RKW 24-27K, RKW 28-23K,
RKW 48-13K

IMPORTANT NOTES:

- 1) The contents of this manual are protected by copyright. Reproduction of any part can be made only with the specific written permission of Kepco, Inc.
- 2) Data subject to change without notice.

©2007, KEPCO, INC
P/N 228-1499-R2



KEPCO, INC. • 131-38 SANFORD AVENUE • FLUSHING, NY. 11352 U.S.A. • TEL (718) 461-7000 • FAX (718) 767-1102
email: hq@kepcopower.com • World Wide Web: <http://www.kepcopower.com>

TABLE OF CONTENTS

SECTION	PAGE
1. Introduction.....	1
1.1 Scope of Manual.....	1
1.2 Description.....	1
2. Specifications	1
3. Operation.....	5
3.1 Voltage Adjustment	7
3.2 Remote Voltage Control	7
3.3 Remote Turn On-Turn Off.....	7
4. Alarm Functions.....	8
4.1 Overvoltage And Overtemperature Protection.....	8
4.2 Overcurrent Protection	8
4.3 Fan Failure	8
4.4 Optical Coupler Output Alarm Circuit.....	8
5. Load Connection	9
5.1 Connecting The Load Using Local Sensing.....	9
5.2 Connecting The Load Using Remote Sensing.....	9
5.3 Parallel Connection	10
5.3.1 Current Balancing	10
5.3.2 Master-Slave Configurations	10
5.3.2.1 Master-Slave, Multiple Loads.....	11
5.3.2.2 Master-Slave, Single Load.....	11
5.4 Series Connection	11
5.5 Preliminary Electrical Check	12
6. Fan Maintenance.....	12

LIST OF FIGURES

FIGURE	TITLE	PAGE
1	Mechanical Outline Drawing Of The RKW 600W Power Supply.....	4
2	Power Rating Vs. Temperature	5
3	Mounting Positions For The RKW 600W Power Supply	5
4	Locations Of Operating Controls, Indicators and Terminals.....	6
5	Connections For Remote Voltage Control.....	7
6	Output Alarm Circuit, Optically Isolated.....	8
7	RKW 300W Power Failure Timing Diagram	9
8	Correct and Incorrect Methods of Load Connection.....	9
9	Parallel Connection with Current Balancing	10
10	Parallel Connection, Master-Slave, Multiple Loads.....	11
11	Parallel Connection, Master-Slave, Single Load	11
12	Series Connection	12
13	Functional Checkout.....	12

LIST OF TABLES

TABLE	TITLE	PAGE
1	Output Ratings and Specifications	1
2	Power Supply Ratings and Specifications	2
3	Function of Controls, Indicators and Terminals	6

1. INTRODUCTION

1.1 SCOPE OF MANUAL

This Operator's Manual covers the installation and operation of the Kepco RKW 600W Series of Switching Power Supplies. For service information, write directly to: Kepco Inc., 131-38 Sanford Avenue, Flushing, New York, 11352, U.S.A. Please state Model Designation and Serial Number of your RKW Power Supply. This information can be found on the nameplate of the unit.

1.2 DESCRIPTION

The Kepco RKW 600W Series consists of seven models of switching power supplies, each with a single output as shown in Table 1. Units may be operated with a nominal 100V a-c to 240V a-c (input voltage range 85 to 265 Va-c), 50-60 Hz (input frequency range 47-66Hz). They will also operate on 110V to 370V d-c input. The RKW 600W Series employs a light weight ferrite core with 140 KHz switching frequency. Regulation is provided by pulse width modulation. A FET power stage, operating in the flyback mode provides a smooth isolated d-c output. A thyristor circuit prevents excessive turn-on current surge. Overvoltage, overcurrent, overtemperature, fan failure and power failure protections and an isolated remote TTL ON-OFF control are provided. An LED "output voltage ON" light and an output voltage adjust trimmer are visible on the terminal side of the case. Units are manufactured on a steel frame with a steel cover.

2. SPECIFICATIONS

Table 1 contains specifications and operating limits of individual RKW 600W Series models. Table 2 contains specifications and operating limits common to all RKW 600W Series Models. These specifications are at nominal input voltages at 25°C unless otherwise specified.

TABLE 1. OUTPUT RATINGS AND SPECIFICATIONS

MODEL RKW 600W		3.3-150K	5-120K	12-53K	15-43K	24-27K	28-23K	48-13K	
Output Volts d-c		3.3V	5V	12V	15V	24V	28V	48V	
Adjustment Range ¹⁾		1.8-3.6	3.5-6.0	7.2-14.4	10.5-18.0	16.8-28.8	19.6-33.6	33.6-52.8	
Voltage Setting		3.3 ±0.03	5 ±0.05	12 ±0.12	15 ±0.15	24 ±0.24	28 ±0.28	48 ±0.48	
Maximum Output Ratings (A,W)	50°C amb	Amps	150	120	53	43	27	23	13
		Watts	495	600	636	645	648	644	624
	60°C, amb	Amps	120	96	42.4	34.4	21.6	18.4	10.4
		Watts	396	480	508.8	516	518.4	515.2	499.2
65°C, amb	Amps	90	72	31.8	25.8	16.2	13.8	7.8	
	Watts	297	360	381.6	387	388.8	386.4	374.4	
Overcurrent Protection (Amps) ¹⁾		156-186	126-156	55.6-68.9	45.1-55.9	28.3-35.1	24.1-29.8	13.7-16.9	
Current Short Circuit		180	160	65	55	35	29	19	
OVP Threshold (Volts) ²⁾		$V_O + 0.66$ to $V_O + 1.32$ (5 max)	$V_O + 1$ to $V_O + 2$ (8 max)	$V_O + 2.4$ to $V_O + 4.8$ (19 max)	$V_O + 3$ to $V_O + 6$ (25 max)	$V_O + 4.8$ to $V_O + 9.6$ (39 max)	$V_O + 5.6$ to $V_O + 10.4$ (44 max)	$V_O + 4.8$ to $V_O + 12$ (60 max)	
Efficiency % typical	AC Input 100V	74	76	80	81	82	82	84	
	AC Input 240V	78	81	84	85	86	86	87	
Ripple & Noise ³⁾ (mV, p-p)	ripple	80	80	150	150	200	200	300	
	ripple noise	120	120	200	200	300	300	400	
<p>(1) Square type. If overcurrent condition continues for approximately 30 seconds, the output is shut OFF. Recovery is by removing and reapplying AC input power, or by reset (open and close) at RC terminal.</p> <p>(2) Overvoltage setting tracks output voltage (V_O). V_O is output voltage set by Vadj (see PAR. 3.1) or remote source (see PAR. 3.2). When overvoltage is detected, output is shut OFF. Recovery is by removing and, after about 40 seconds, reapplying AC input power, or by reset (open and close) at ±RC terminals (no delay).</p> <p>(3) Ripple and noise specifications are within 1.5 times the indicated values for a temperature range of -10 to 0°C. Ripple and noise levels above are satisfied when conditions are 0 to 100% load, 0 to 65°C (derated from 50 to 65°C per Figure 2), and bandwidth ≤ 100MHz.</p>									

TABLE 2. POWER SUPPLY RATINGS AND SPECIFICATIONS

SPECIFICATION	DESCRIPTION		
Input Voltage	Nominal: 100-120V a-c or 200-240Va-c	Range: 85-265V a-c (0 to 100% load, -10 to 65°C)	
	Range 110-370 Vdc	(0 to 100% load, -10 to 65°C)	
Input Source Frequency	Nominal 50/60 Hz, Range 47-66 Hz. (At 400 Hz the leakage current exceeds the VDE leakage safety specification limit).		
Input Current: (Maximum Load At 25°C with Nominal Output Voltage)	100 - 120V a-c	8.4A rms max. (7.2A rms max for the 3.3V model)	
	200 - 240V a-c	4.2A rms max. (3.6A rms max for the 3.3V model)	
Input Protection	A thyristor circuit reduces start-up surge. Units are protected against shorts by an input fuse. Fuse value 15.0A At 250 Volts		
Input Surge cold start, interval > 30 sec ⁽¹⁾	100 - 120V a-c	15A typ., 30A max. first surge	
	200 - 240V a-c	30A typ., 60 max. first surge	
Leakage Current:	0.45mA typ., 0.75mA max. at 120V a-c, 60Hz (per IEC 950 and UL1950) 0.60mA typ., 0.75mA max. at 240V a-c, 60Hz (per IEC 950 and UL1950)		
Power Factor	100V a-c	0.99 typical	
	200V a-c	0.95 typical	
Stabilization	Source Effect (min - max) (85 to 132 V a-c, 170 to 265V a-c)	Typical	Maximum
		0.1% (0.15% for 3.3V Model)	0.2% (0.3% for 3.3V Model)
	Load Effect, measured at DC output terminals (0%-100% load change)	0.3% (0.45% for 3.3V Model)	0.6% (0.9% for 3.3V Model)
	Temperature Effect (-10° to 71°C)	0.5%	1.0%
	Combined Effect (envelope, Source, Load and Temperature)	±0.9% (±1.1% for 3.3V Model)	±1.8% (±2.2% for 3.3V Model)
	Drift (from 1/2 to 8 hours at 25°C)	0.2%	0.5%
Remote Error Sensing:	Compensation up to 0.4 Volts per load wire (0.15 Volts for RCW 3.3-70K, 0.25 Volts for RCW 5-70K) (see Figure 8).		
Transient Recovery characteristic	excursion	±4% maximum	50% to 100% load, transient time >50µsec
	recovery time	1 ms maximum	
Start-up Time	100 - 120V a-c	350 msec maximum, 280 msec typical.	
	200 - 240V a-c	150 msec maximum, 100 msec typical.	
Output Hold-up Time	100 - 120V a-c	30 msec typical, 20 msec minimum.	
	200 - 240V a-c	40 msec typical, 20 msec minimum.	
Overvoltage Protection	When the Power Supply goes into an overvoltage condition, the output is cut OFF. To restart (reset) the unit, it is necessary either to remove the a-c input power, wait about 40 seconds, and then to reconnect the a-c input power, or reset using remote ON-OFF feature (see PAR. 3.3).		
Remote Control ON/OFF:	"High", 2.4V to 24V (or open), unit OFF- Fan Off ; "Low", 0.0V to 0.4V (or closed), unit ON. Source current is 1.6mA maximum, sink current 1.0 mA maximum. The ±RC terminals are isolated from the a-c input terminal and the DC output terminals. When remote ON/OFF is not in use, ±RC terminals must be shorted (use shorting link supplied) for unit to operate.		
Operating Temperature:	-10 to 65°C (see Figure 2)		
Startup Temperature	-10 to -20°C (see Figure 2)		
Storage Temperature:	-30°C to +75°C		
(1) First surge only, not including current flow into EMI filter.			

TABLE 2. POWER SUPPLY RATINGS AND SPECIFICATIONS (CONTINUED)

SPECIFICATION	DESCRIPTION	
Isolation: (at 15-35°C ambient, 10-85% relative humidity)	Between input and case	2000Va-c for 1 minute. Cutout current is 20mA
	Between output and case	500Va-c for 1 minute. Cutout current is 100mA
	Between input and output terminal	2000Va-c for 1 minute. Cutout current is 20mA
Insulation Resistance: (at 15-35°C ambient, 10-85% relative humidity)	Between output and case, input and case, and input and output, 100 Megohms minimum (500Vdc)	
Humidity:	10% to 95% relative humidity, noncondensing, Wet Bulb temperature < 35°C	operating and non-operating
Vibration:	5-10 Hz., 10mm amplitude, 10-200 Hz., acceleration 64.3ft./s ² (19.6m/s ²) (2g)	non-operating, 1 hr. on each of 3 axes, Power Supply is fixed on its bottom side)
Shock: (non-operating, 1/2 sine pulse, three shocks on each axis, Power Supply is fixed on its bottom side)	964.6ft./s ² (294m/s ²) (30g), 11ms ± 5 msec pulse duration	
EMI Conducted:	FCC Class B, VCCI-Class B, EN55011-B, EN55022-B	
Safety:	All units designed to meet UL1950, CSA Electrical Bulletin 22.2 No.950-95 (certified by UL), and TÜV Rheinland EN60950 (ambient temp. 50°C max.). RKW 600W units are CE marked per the Low Voltage Directive (LVD), 73/23/EEC and 93/68/EEC. [The standards do not apply with DC input operation]	
EMI radiated, conducted:	FCC Class B, VCCI-Class B, EN55011-B, EN55022-B	
ESD immunity:	EN61000-4-2, level 4	normal operation
Electrical fast transient burst:	EN61000-4-4 level 3	normal operation
Surge withstand:	EN61000-4-5, level 4	normal operation
Power Frequency Magnetic Field:	EN61000-4-8, level 4	normal operation
Radiated susceptibility:	EN61000-4-3 level 3	normal operation
Conducted susceptibility:	EN61000-4-6 level 3	normal operation
Voltage dips interruptions and variations	EN61000-4-11	normal operation
Input harmonics current:	EN61000-3-2	
Dimensions:	3.62 in. (92 mm) x 4.72 in. (120 mm) x 7.87 in. (200 mm)	
Mounting:	No. M4 tapped holes	
Maximum Screw Penetration:	0.24 in. (6 mm)	
Cooling:	Forced air flow - one fan	
Frame Material/Cover Material:	Steel	
Weight:	5.95 lbs. (2.7 Kg) typical, 6.61 lbs. (3.0 Kg) maximum	

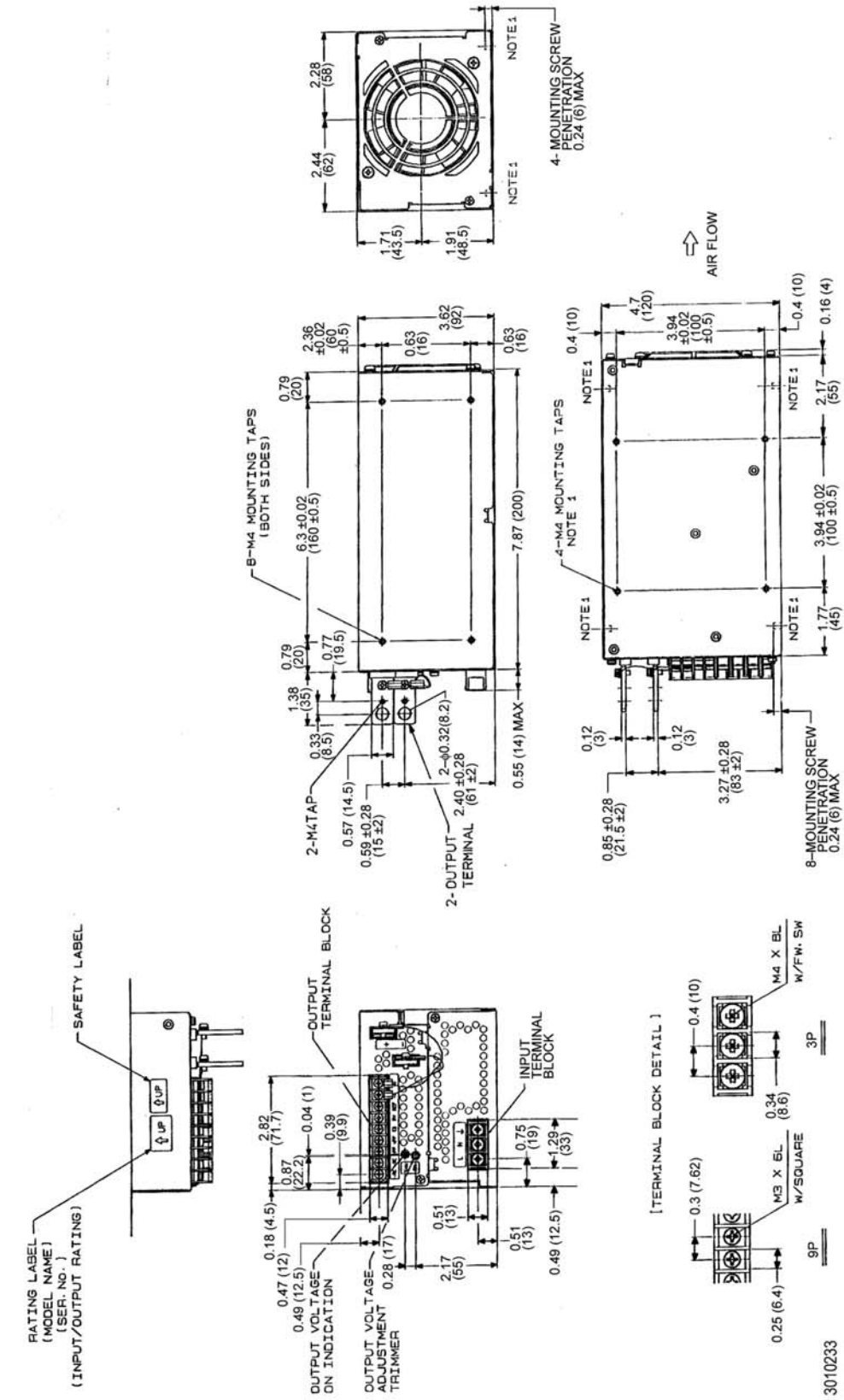

- NOTES:
1. MOUNTING SCREW PENETRATION: 0.24 inches [6 mm] maximum
 2. TOLERANCES: ±0.04" [±1.0 mm] unless specified.
 3. Dimensions are in inches brackets are in millimeters.
 4. WEIGHT: 5.95 lb. (2.70 Kg.) typ, 6.6 lb. (3.0 Kg.) max.

FIGURE 1. MECHANICAL OUTLINE DRAWING OF THE RKW 600W POWER SUPPLY

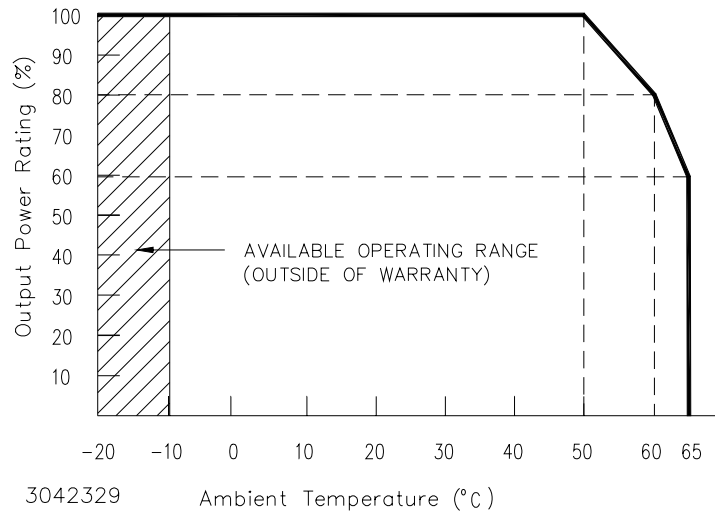

FIGURE 2. POWER RATING VS. TEMPERATURE

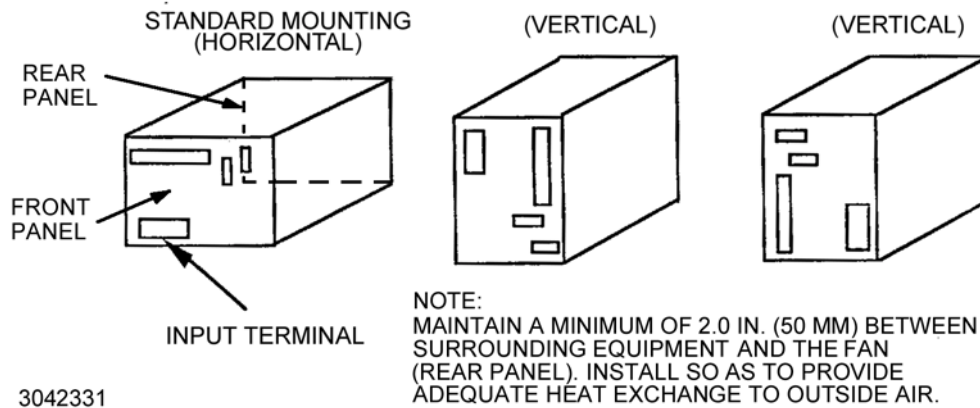

FIGURE 3. MOUNTING POSITIONS FOR THE RKW 600W POWER SUPPLY

3. OPERATION

Figure 4 shows the location of all operating controls and input/output terminals followed by an explanation of each. The unit is shipped with shorting links installed connecting the following terminals: +RC to -RC and REF to RV. A local sensing cable is also installed, connecting +DC Output with +S and -DC Output with -S for local sensing.

NOTES:

- +S and -S MUST be properly connected for the unit to operate. For local sensing, leave local sense cable in place (refer to PAR. 5.1). For remote sensing (at the load), refer to PAR. 5.2.**
- If remote ON/OFF is not being used, ±RC terminals must be connected (use shorting link supplied) for unit to operate.**

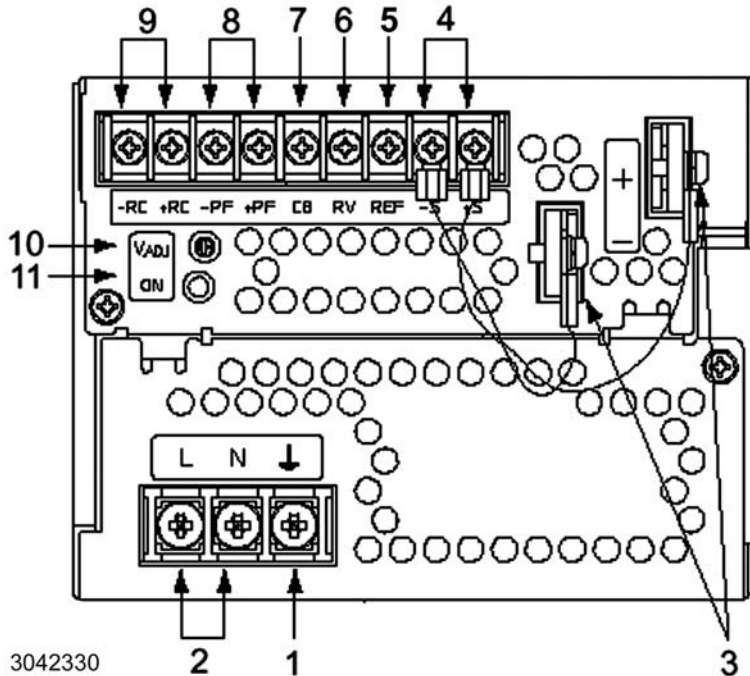

NOTE Unit is shipped with shorting links (not shown) connecting +RC to -RC (see PAR. 3.3) and REF to RV (see PAR. 3.2) installed and with local sensing cable installed (connects +DC Output to +S and -DC Output to -S) (see PAR. 5.2)

FIGURE 4. LOCATIONS OF OPERATING CONTROLS, INDICATORS AND TERMINALS

TABLE 3. FUNCTION OF CONTROLS, INDICATORS AND TERMINALS

FIG. 4 INDEX NO.	CONTROL, INDICATOR, TERMINAL	FUNCTION
1	Frame Ground (earth)	Connect to earth ground. This terminal is connected to the case.
2	A-C Input (L, N)	Connect to AC: 100 to 120V AC or 200 to 240V AC input line.
3	DC Output (+, -)	Connect to load (see Figure 8).
4	Sense (+S, -S)	Used to compensate for voltage drop in the connecting lines from the output terminal to a load; they are connected to \pm DC Output terminals for local sensing (see Figure 8).
5	Output Voltage Reference (REF)	Using REF terminal (together with the RV terminal) allows all the output voltages of slave power supplies to be controlled by one voltage adjustment of a master power supply (normally connected to the RV terminal with a metal shorting link).
6	Output Voltage Adjust (RV)	This terminal (together with the REF terminal) is used for remotely controlling output voltage (see PAR. 3.2).
7	Current Balance (CB)	This terminal is used when several power supplies are connected in parallel (see PAR. 5.3).
8	Power Failure (PF)	These terminals output an open logic signal if output voltage drops to 80 % or lower of a set voltage, or if output voltage is shut down due to overvoltage or overcurrent protection, fan speed failure, or overheating. (see Figure 6).
9	Remote ON-OFF (+RC, -RC)	Output is turned ON-OFF by shorting-opening the RC terminals (output OFF when open). RC terminals are isolated from input and output terminals. Normally, \pm RC terminals are shorted with a metal shorting link (see PAR. 3.3).
10	Output Voltage Trim Adjust (Vadj)	Adjusts output voltage.
11	Output Voltage On indicator (green)	Green LED lights when output voltage is present.

3.1 VOLTAGE ADJUSTMENT

Output voltage can be manually adjusted with the voltage adjustment control, Vadj (see Figure 4). To adjust voltage, first place the unit under an operating load, then monitor the (+)S and (-)S Sense terminals with a precision voltmeter and turn the voltage control to the desired operating value. Refer to Table 1 for the recommended Adjustment Range of all the RKW 600W Models .

NOTE: Actual output voltage can exceed recommended range values.

3.2 REMOTE VOLTAGE CONTROL

The unit is shipped with a shorting link in place between RV and REF terminals. Removal of this link allows the output voltage to be adjusted by either a trimmer pot (resistance) or by an external variable voltage source using the RV terminal.

NOTE: If remote voltage control is not implemented, the shorting link between RV and REF must be in place.

Use either local sensing (PAR. 5.1) or remote sensing (PAR. 5.2). If remote sensing is used, the impedance of the load wires connecting each power supply to the load should be the same. It is possible that the overvoltage protection may be triggered if the external programming voltage source is changed very quickly (using either the Vadj pot or the RV terminal) when the power supply is at a low load condition.

RESISTANCE. Use a shielded wire, 2m maximum in length, for connection to the trimmer control. Connect the external trimmer as shown in Figure 5 (A). Suggested value for the trimmer control is 5K ohms). With the external trimmer control at its maximum clockwise position, set the output voltage to the desired maximum value by adjusting Vadj clockwise. The value should not be more than 120% of E_o nominal (not more than 110% for the 48-volt model, not more than 3.6V for the 3.3-volt model).

VOLTAGE. By adjusting an external 0-6V voltage source (0-5.5V for the 48-volt model) from minimum to maximum, the maximum output voltage can be adjusted from 0 to 110% (the 3.3-volt model can be adjusted to 3.6V). Remove the shorting link between the REF and RV terminals. Connect the voltage source across the RV and (-)S terminals as shown in Figure 5 (B).

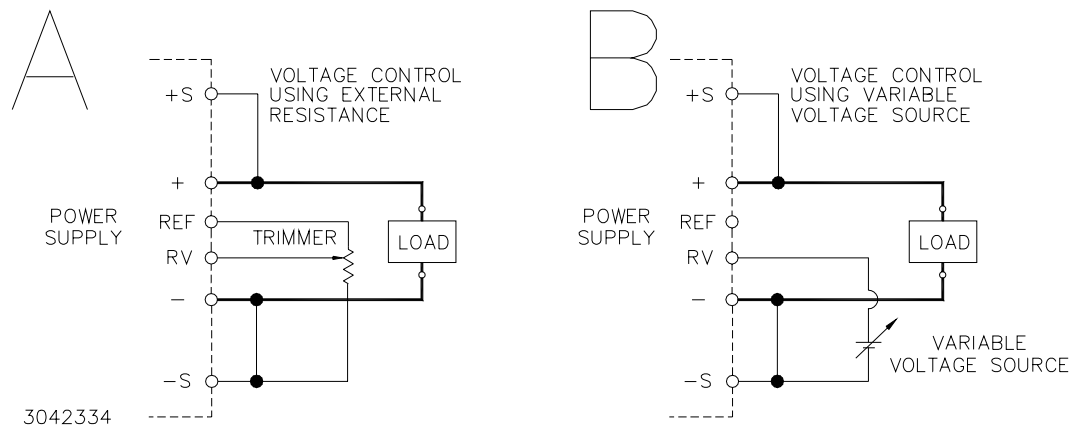

FIGURE 5. CONNECTIONS FOR REMOTE VOLTAGE CONTROL

3.3 REMOTE TURN ON-TURN OFF

When input source power is ON, the output may be turned ON or OFF with the remote control feature using the \pm RC terminals (see Figure 4). These terminals accept a logic level (2.4V to 24V "high" and 0.0 to 0.4V "low"), or a contact closure. When the \pm RC terminals are open, using either a mechanical switch or a high level logic signal, the RKW 600W output is cut OFF. When the RC

terminals are shorted, the output returns to within specifications. At low level logic, the maximum source current is 1.6mA, at high logic level the maximum sink current is 1.0mA. The RC terminals must remain shorted if remote ON-OFF is not used. The RC terminals are isolated from both the AC input and DC output terminals. Remote ON-OFF offers the advantages of low inrush current and no delay on restarts.

4. ALARM FUNCTIONS

4.1 OVERVOLTAGE AND OVERTEMPERATURE PROTECTION

When the output voltage or the internal temperature of the RKW 600W Power Supply increases beyond the specified values (see Table 1), the output is cut OFF and the fan turns OFF. Overvoltage setting tracks output voltage up to maximum specified in Table 1. To restart (reset) the unit, remove AC input power, wait about 40 seconds, then reconnect AC input power. The power supply can also be reset with no delay using the remote ON-OFF feature (see PAR. 3.3).

If the Power Supply shuts down due to an increase in internal temperature, the restart cycle (Power ON) should not begin until the temperature returns to within specifications.

The alarm circuit is a diode transistor optical coupler. The transistor is normally conducting. When the alarm activates, the transistor cuts off and the collector emitter circuit opens (see PAR. 4.4).

4.2 OVERCURRENT PROTECTION

The overcurrent setting has a square type characteristic, and the unit is set to shut down if output current exceeds specifications (see Table 1) for more than 30 seconds. To restart (reset) the unit, remove AC input power, wait about 40 seconds, then reconnect AC input power. The power supply can also be reset with no delay using the remote ON-OFF feature (see PAR. 3.3).

4.3 FAN FAILURE

A decrease in fan speed causes the output to shut down and the fan to turn OFF. Fan failure is indicated by an open circuit across the (\pm) PF terminals (see PAR 4.1). To restart (reset) the unit remove the AC input power, wait about 40 seconds, then reconnect AC input power. The power supply can also be reset with no delay using the remote ON-OFF feature (see PAR. 3.3).

4.4 OPTICAL COUPLER OUTPUT ALARM CIRCUIT

When the output voltage falls to less than about 80 percent of programmed output voltage the alarm is activated: a high logic level appears at the \pm PF terminals (see Figures 6 and 7). The default state of the alarm is logic low. The sink current is 50mA maximum, the maximum collector to emitter saturation voltage is 0.40 Volts, and the collector to emitter voltage is 40 volts maximum. The PF terminals are isolated from the AC input and DC output terminals. Insulation resistance between the PF terminals and the AC input terminals is the same as the insulation resistance between the input and output. Insulation resistance between the PF terminals and the output terminals is the same as the insulation resistance between the output and ground.

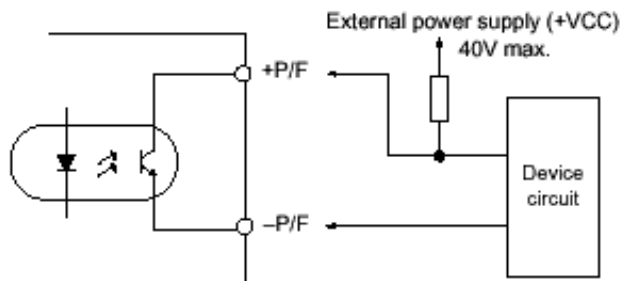

FIGURE 6. OUTPUT ALARM CIRCUIT, OPTICALLY ISOLATED

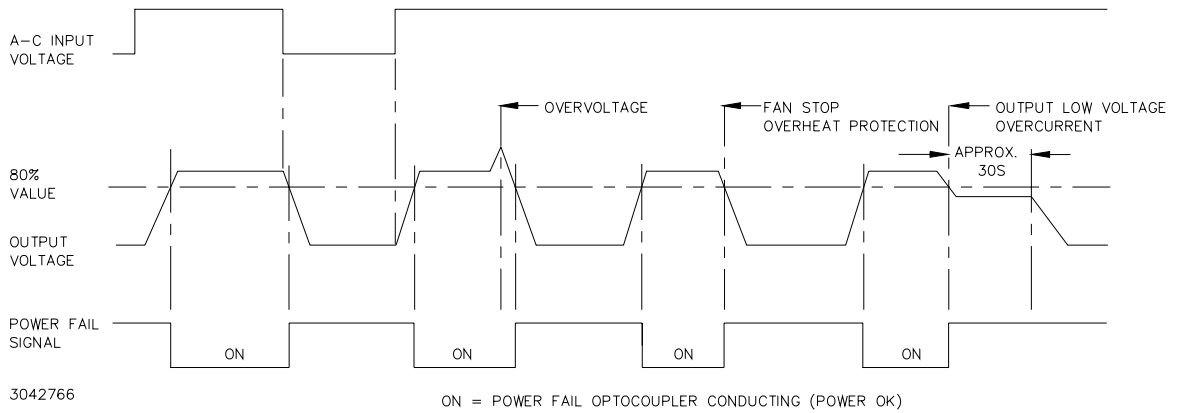

FIGURE 7. RKW 600W POWER FAILURE TIMING DIAGRAM

5. LOAD CONNECTION

5.1 CONNECTING THE LOAD USING LOCAL SENSING

To connect the load for local sensing, the local sensing cable supplied must be installed to connect the +S terminal with DC Output (+), and -S terminal with DC Output (-). The load is connected across DC output (+) and (-) (see Figure 8).

5.2 CONNECTING THE LOAD USING REMOTE SENSING

For remote sensing the load is connected as shown in Figure 8. Remote error sensing at the load terminals compensates for voltage drop in the connecting wires as indicated in Table 2. For remote sensing, the local sensing cable must be removed from the ±S and ±DC Output terminals. NOTE: If the overvoltage protection trips too easily, install one external electrolytic capacitor, rated 470µF min. between the +DC Output and +S terminals and one between the -DC Output and -S terminals.

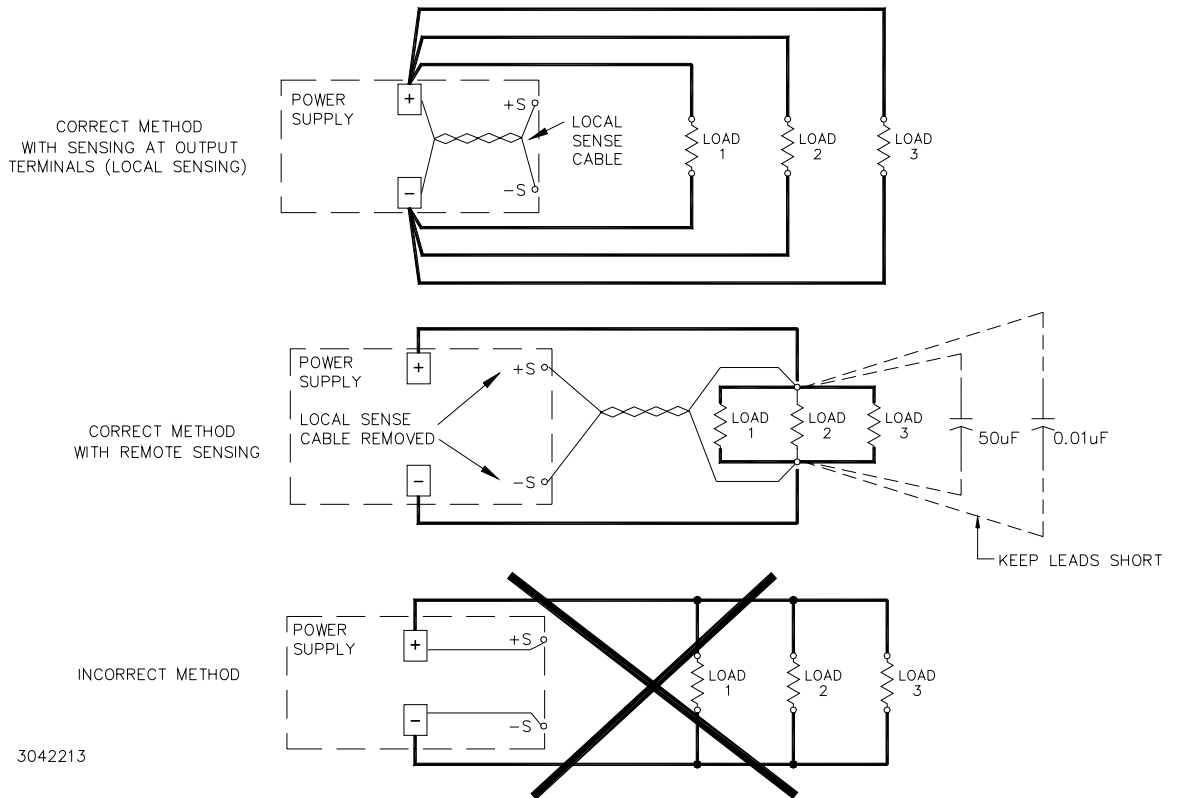

FIGURE 8. CORRECT AND INCORRECT METHODS OF LOAD CONNECTION

5.3 PARALLEL CONNECTION

Identical RKW 600W Power Supplies can be connected in parallel (with or without N+1 redundancy). Current balancing per PAR 5.3.1 can be implemented. Parallel units can be configured in a master-slave configuration so that all units can be adjusted using on Vadj control, either for multiple loads (PAR 5.3.2.1) where current draw is dependant upon the individual loads, or for a single load (PAR 5.3.2.1), where current balancing (forced current sharing) per PAR 5.3.1 equalizes the load among the parallel-connected units.

For a single remote ON-OFF signal to turn off all parallel-connected units, connect together all +RC terminals and connect together all -RC terminals.

Figure 9 illustrates connection of up to four (maximum) power supplies in parallel. Output current for a parallel connection operating into a single load must be equalized per PAR 5.3.1 after connecting the CB terminals as shown in Figure 9. Refer to PAR. 5.3.1 for conditions required for proper current equalization (balancing).

N+1 Redundancy. An N+1 system requires one additional power supply than necessary to supply the load. If one of the parallel-connected units fail, the others will seamlessly provide power to the load without down time. For N+1 redundancy, add isolation diodes as shown in Figure 9.

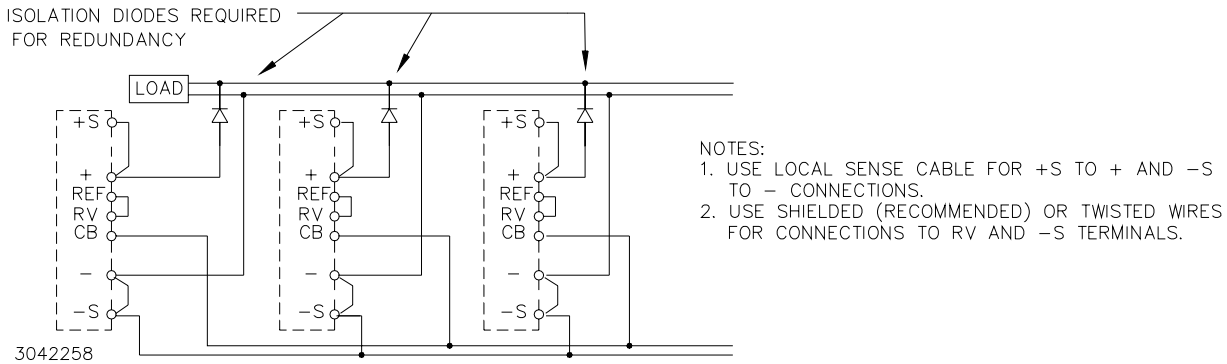

FIGURE 9. PARALLEL CONNECTION WITH CURRENT BALANCING

5.3.1 CURRENT BALANCING

Current balancing (equalization) conditions required for up to four RKW 600W units in parallel are:

1. Output current of each power supply should be within 20 to 90% of the total output current rating.
2. The output voltage of any Power Supply individually must be within 2% maximum of the other power supplies' output voltage setting.

$$\frac{\text{Maximum Voltage} - \text{Minimum Voltage}}{\text{Rated Voltage}} = 2\% \text{ variation of output voltage in each power supply}$$

3. The expected current sharing is such that the output current variation for each power supply is less than or equal to 10% of each power supply rated output current.

5.3.2 MASTER-SLAVE CONFIGURATIONS

Master-slave operation allows the output voltage of all the power supplies connected in parallel to be adjusted using the Vadj control on the designated master power supply.

5.3.2.1 MASTER-SLAVE, MULTIPLE LOADS

Figure 10 shows the master-slave connection of three power supplies in parallel, each having an independent load, with output voltage controlled by the V_{adj} control of the master power supply. Use shielded wire (recommended) or twisted wires for connections to RV and $-S$ terminals.

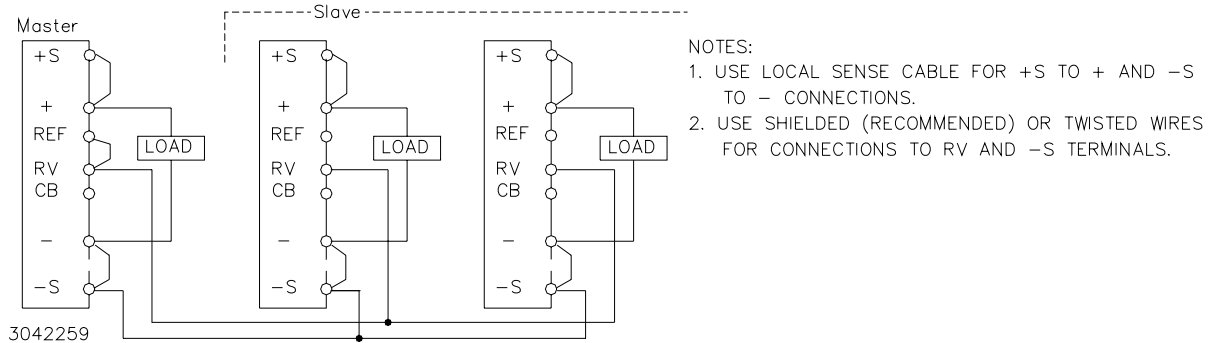

FIGURE 10. PARALLEL CONNECTION, MASTER-SLAVE, MULTIPLE LOADS

5.3.2.2 MASTER-SLAVE, SINGLE LOAD

Figure 11 shows the connection of three power supplies in parallel to a single load. The output voltage of all power supplies is controlled by V_{adj} of the master. Current balancing must be implemented to equalize the load (see PAR. 5.3.1). NOTE: Use shielded wire (recommended) or twisted wires for connections to RV and $-S$ terminals. Match impedance of load wires between each power supply and load by using the same wire lengths and wire sizes.

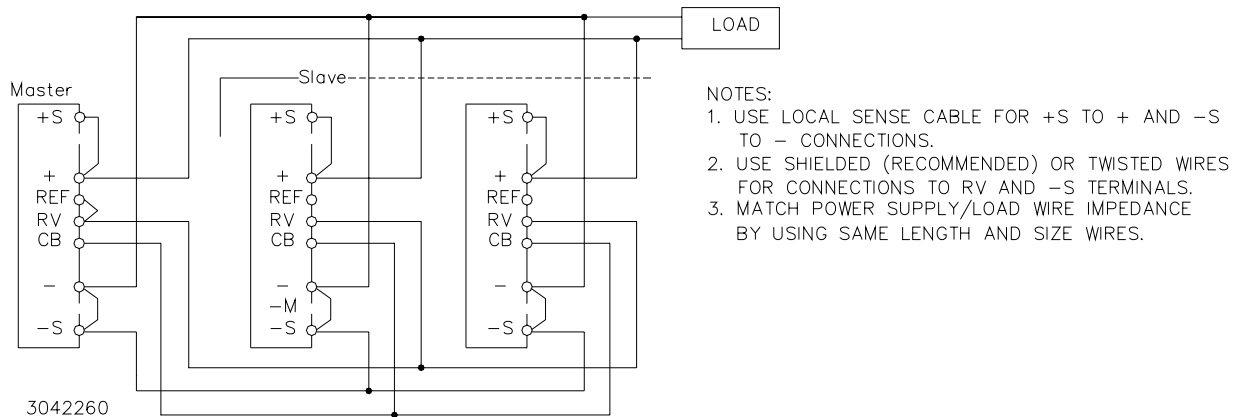
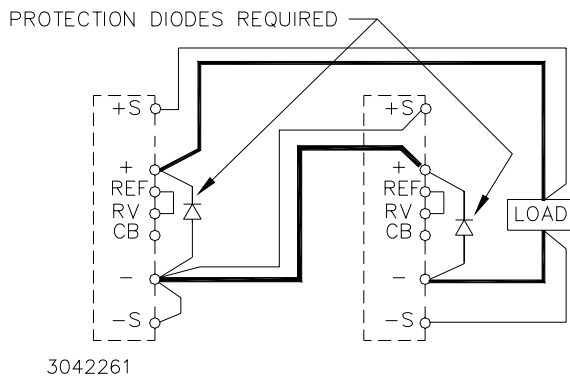

FIGURE 11. PARALLEL CONNECTION, MASTER-SLAVE, SINGLE LOAD

5.4 SERIES CONNECTION

Units may be connected in series to obtain higher voltages. When a number of power supplies are operating in series, the current rating is to be limited to the rating of the power supply with the lowest rating. Each Power Supply in series should be protected by a diode connected in its non-conducting direction in parallel with the output as shown in Figure 12. The diode protects against inadvertent shorting of the series connection. It should be rated for the maximum voltage and current of the series connection (typically, $V_{REVERSE} = 2 \times V_{OUT}$ of the series connection, $I_{FORWARD} = 2 \times I_{OUT}$ of the series connection). This may require several diodes in parallel to meet high current requirements.



NOTES:

1. REMOTE SENSING SHOWN.
2. FOR LOCAL SENSING, REMOVE SENSE CONNECTIONS FROM THE LOAD AND BETWEEN - AND S+ OF THE TWO POWER SUPPLIES. INSTALL LOCAL SENSE CABLES (+S TO +, AND -S TO -) ON BOTH POWER SUPPLIES.
3. USE SHIELDED (RECOMMENDED) OR TWISTED WIRES FOR CONNECTIONS TO +S AND -S TERMINALS.

FIGURE 12. SERIES CONNECTION

5.5 PRELIMINARY ELECTRICAL CHECK

Connect an adjustable load across the power supply output terminals, on the right side terminal barrier strip on the front panel (see Figure 4). The load must have a dissipation rating of at least 700 Watts. Connect a voltmeter and an oscilloscope across the power supply sense terminals +S and -S. The oscilloscope must be isolated from the source and grounded at the load. Use an isolation transformer between the test equipment and the AC input power (see Figure 13).

Connect the AC input power to the line, neutral and ground terminals (see Figure 4). Turn input power on and check the output voltage both with and without load. The output voltage can be adjusted within the published range by using the front panel voltage control trimmer Vadj.

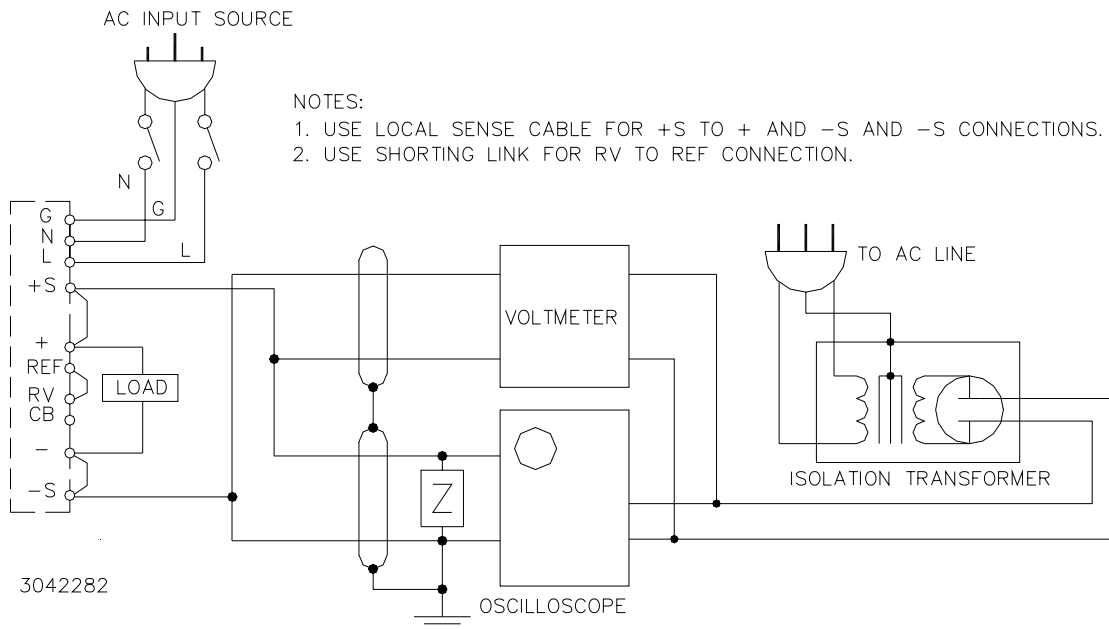

FIGURE 13. FUNCTIONAL CHECKOUT

6. FAN MAINTENANCE

Under most conditions the fan requires no maintenance. Do not use the fan in an environment of high temperature and high humidity that exceeds the temperature and humidity limits given in the Power Supply Specifications (see Table 2). Avoid an environment where corrosive gas may be present. If the Power Supply is used in an open or dirty area, a filter should be installed on the air intake side of the fan to prevent the inflow of dust particles. If the Power Supply is used in briny air care should be taken to keep the salt from entering the Power Supply.

You must register your product to comply with the terms of the warranty. Either fill out the form below and mail or fax to Kepco, or for rapid on-line registration go to:

<http://www.kepcopower.com/warranty.htm>

PRODUCT PURCHASED:

Model Number) _____

Serial Number _____

PURCHASE INFORMATION:

Date Purchased: _____

Date Received: _____

REQUEST ADDITIONAL INFORMATION

Send complete Catalog

Have Sales Engineer Call

Contact via: E-Mail Telephone Fax S-mail

REGISTER TO:

Registered by: _____

Company Name: _____

Street: _____

City: _____

State: _____

Country: _____

Zip: _____

E-mail: _____

FAX: _____

Phone: _____

WHAT INFLUENCED YOUR CHOICE OF THIS POWER SUPPLY?

Previous Experience (which Kepco Models do you have?)

Magazines (which ones?) _____

Trade Shows (which ones?) _____

Directory? _____

Kepco Catalog or Brochure? _____

Sales Representative?

Web Site

Other (please explain): _____

What products would you like to see Kepco make?

CUT HERE

Kepco 5 Year Warranty

This is to certify that we, KEPCO, INC., (hereinafter called "Company"), Flushing, NY 11352 USA, warrants for a period of FIVE YEARS, this instrument known as:

MODEL: _____

SERIAL NO. _____

The Company's products are warranted for a period of five years from date of delivery to be free from defects in materials and workmanship and to conform to the specifications furnished or approved by the Company. Liability under this warranty shall be limited to the repair or replacement of any defective product at Company's option.

If any defect within this warranty appears within the warranty period, the Purchaser shall promptly notify the Company in writing. No material will be accepted for repair or replacement without written authorization of the Company.

Upon such authorization, and in accordance with instructions of the Company, parts or materials for which replacement is requested shall be returned to the Company for examination, with shipping charges prepaid by the Purchaser. Final determination as to whether a product is actually defective rests with the Company.

This warranty does not extend to any product which has been subjected to misuse, neglect, accident, improper installation, or use in violation of instructions furnished by the Company. The warranty does not extend to, or apply to, any unit which has been repaired or altered outside of the Company's factory by persons not expressly approved by the Company.

THE WARRANTY HEREIN CONTAINED IS IN LIEU OF AND EXCLUDES ALL OTHER WARRANTIES, EXPRESS, IMPLIED OR STATUTORY, INCLUDING WITHOUT LIMITATION THE WARRANTY OF MERCHANTABILITY.

THIS KEPCO PRODUCT IS WARRANTED FOR FIVE YEARS!

KEPCO, INC. • 131-38 SANFORD AVENUE, FLUSHING,
NY 11352 USA • Tel. 718-461-7000 • Fax. 718-767-1102
E-mail: hq@kepcopower.com • URL: <http://www.kepcopower.com>



FOLD HERE

Please
place
stamp
here

KEPCO, INC.

131-38 SANFORD AVE.
FLUSHING, NY 11352 USA

CUT HERE